

specifications

PG500Pizza

SKOPE Pegasus Horizontal 2/1
INTEGRAL 2 Door Pizza Chiller (JK9302)

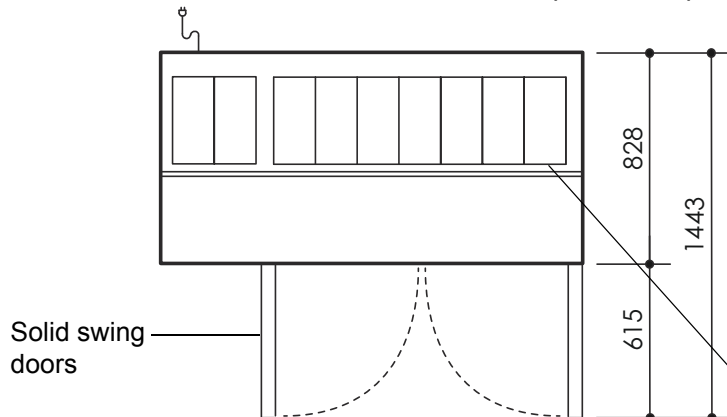

CABINET DIMENSIONS

	External	Internal
Height:	900mm*	565mm
Width:	1750mm	1250mm
Depth:	830mm	650mm
Floor area:	1.45m ²	

* Height includes plinth and worktop (excludes castors and adjustable legs).

7 x 1/3 150mm deep pans (refrigerated)
2 x 1/3 65mm deep pans (ambient)

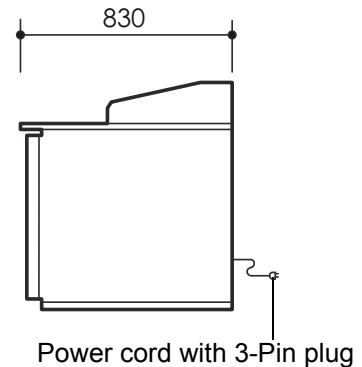
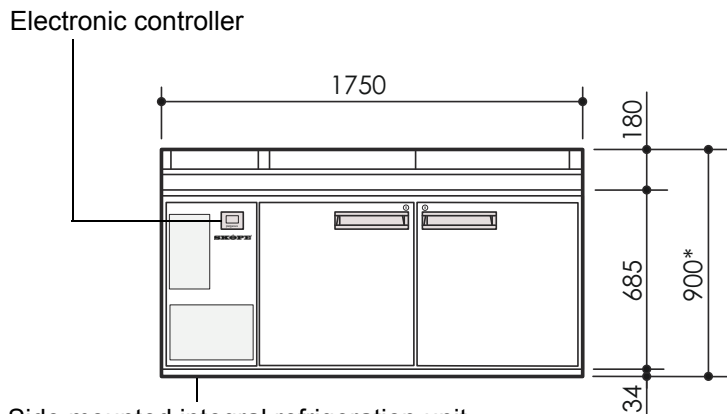

Side mounted integral refrigeration unit

Copyright © 2012 SKOPE Industries Limited

CABINET SPECIFICATIONS

Refrigeration system:	Electronic controlled, side mounted, integral refrigeration unit
Refrigerant:	R134a / 800g
Nominal capacity:	706 Watts @ -10°C SST
Cabinet internal volume:	480 litres
Insulation:	60mm thick, high density cyclo-isopentane polyurethane foam
Cabinet temperature range:	+1°C to +5°C up to 30°C ambient
Drainage:	Evaporator drain fitted inside service compartment (requires plumbing)
Electrical:	230-240 Volts a.c. 50 Hz, 3.43 Amps
Internal lighting:	n.a.
Internal door opening size:	2 door openings: 565mm high x 565mm wide
Doors:	Solid stainless steel, self-closing doors (with key lock) - LH, LH, RH hinged
Worktop:	Worktop accepts 7 x 1/3 150mm deep refrigerated pans & 2 x 1/3 65mm deep ambient pans
Shelves:	2 shelves & adjustable tray slides per door (530mm wide x 650mm deep)
Weight:	145 kg

SKOPE Industries Limited reserve the right to alter specifications without notice.

PSS0325 Rev 1.0 Dec. 2012



SKOPE INDUSTRIES LIMITED



New Zealand Freephone: 0800 947 5673, Fax: (03) 983 3896. Australian Freephone: 1800 121 535, Freefax: 1800 121 533

Email: enquiry@skope.co.nz Website: www.skope.co.nz