

# specifications

## PG250Prep-2

SKOPE GEN 2: Pegasus Horizontal 1/1  
INTEGRAL 2 Door Prep Chiller (JH7302)

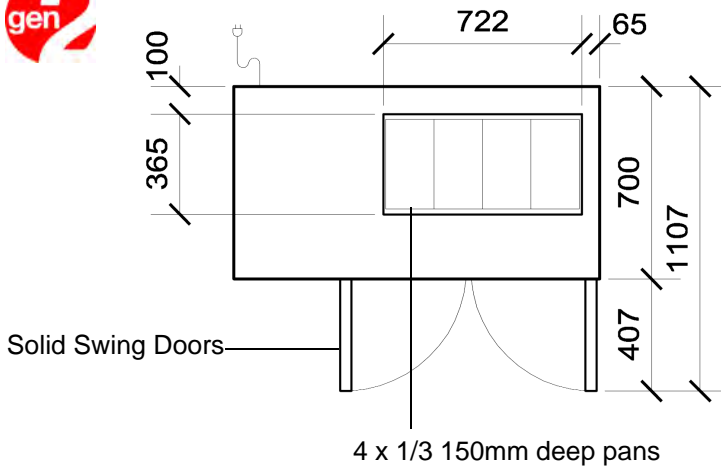

### CABINET DIMENSIONS

	External	Internal
<b>Height:</b>	751mm*	570mm
<b>Width:</b>	1331mm	833mm
<b>Depth:</b>	700mm	545mm
<b>Floor area:</b>	0.93m <sup>2</sup>	

\* Height excludes castors or legs.

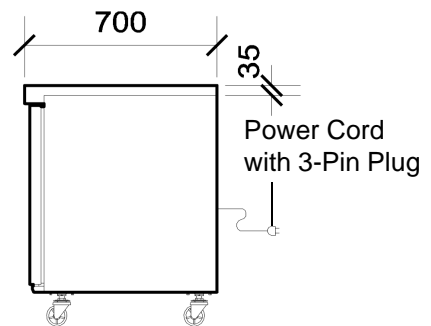
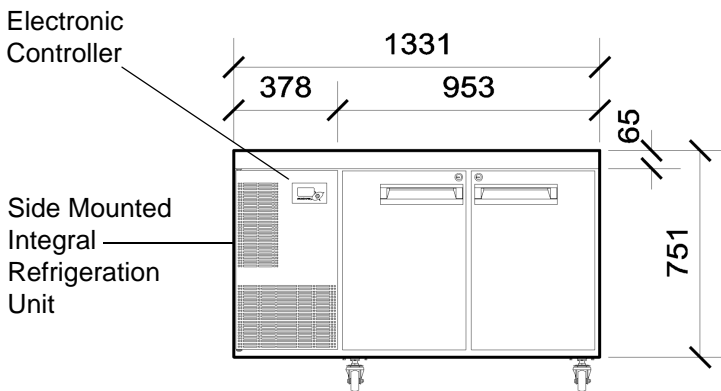

Copyright © 2008 SKOPE Industries Limited

### CABINET SPECIFICATIONS

<b>Refrigeration system:</b>	Electronic controlled, side mounted, integral refrigeration unit
<b>Refrigerant:</b>	R404A / 700g
<b>Nominal capacity:</b>	500 Watts
<b>Cabinet internal volume:</b>	260 litres
<b>Insulation:</b>	60mm thick, high density cyclo-isopentane polyurethane foam
<b>Cabinet temperature range:</b>	+1°C to +4°C up to 30°C ambient
<b>Drainage:</b>	No plumbing required
<b>Electrical:</b>	230-240 Volts a.c. 50 Hz, 3.77 Amps
<b>Internal lighting:</b>	1 x 5W T8 LED tube (Ø26 x 360mm) - Door activated
<b>Internal door opening size:</b>	2 door openings: 570mm high x 365mm wide
<b>Doors:</b>	Solid stainless steel, self-closing doors (with key lock) - LH & RH hinged
<b>Worktop:</b>	Worktop accepts 4 x 1/3 150mm deep pans or 8 x 1/6 150mm deep pans
<b>Shelves:</b>	Two levels of non-tip, adjustable tray slides and/or shelves per door
<b>Weight:</b>	160 kg

SKOPE Industries Limited reserve the right to alter specifications without notice.

Rev 2.0 Nov. 2011



**SKOPE INDUSTRIES LIMITED**

New Zealand Freephone: 0800 947 5673, Fax: (03) 983 3896. Australian Freephone: 1800 121 535, Freefax: 1800 121 533

Email: enquiry@skope.co.nz Website: www.skope.co.nz

