

specifications

PG550Prep-2

SKOPE GEN 2: Pegasus Horizontal 1/1
INTEGRAL 4 Door Prep Chiller (JH7304)

CABINET DIMENSIONS

	External	Internal
Height:	751mm*	570mm
Width:	2267mm	1769mm
Depth:	700mm	545mm
Floor area:	1.59m ²	

* Height excludes castors or legs.

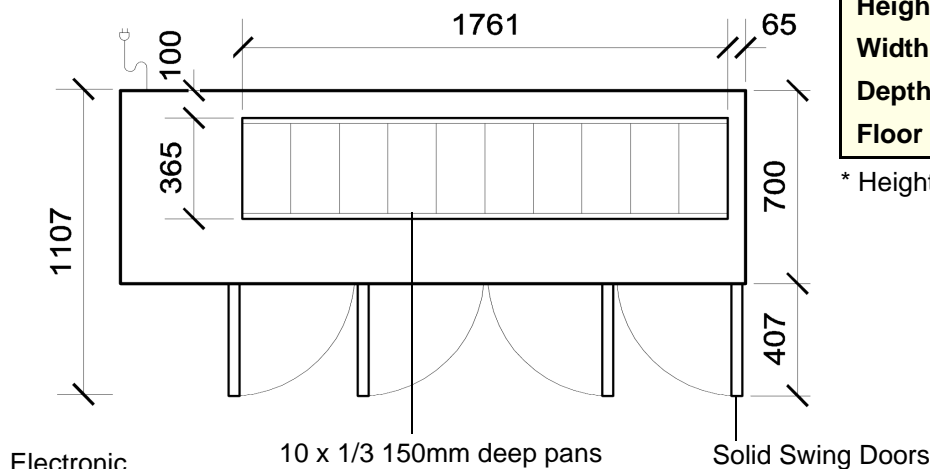

Electronic
Controller

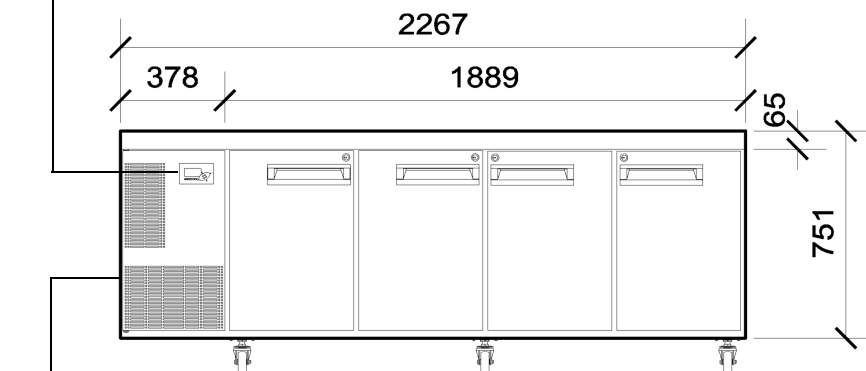

Side Mounted Integral Refrigeration Unit

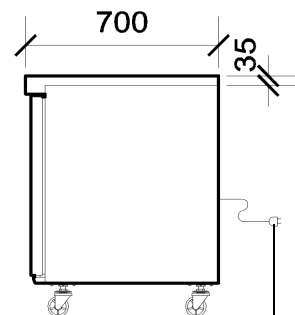

Power Cord with 3-Pin Plug

Copyright © 2008 SKOPE Industries Limited

CABINET SPECIFICATIONS

Refrigeration system:	Electronic controlled, side mounted, integral refrigeration unit
Refrigerant:	R404A / 850g
Nominal capacity:	1180 Watts
Cabinet internal volume:	560 litres
Insulation:	60mm thick, high density cyclo-isopentane polyurethane foam
Cabinet temperature range:	+1°C to +4°C up to 43°C ambient
Drainage:	No plumbing required
Electrical:	230-240 Volts a.c. 50 Hz, 5.26 Amps
Internal lighting:	2 x 5W T8 LED tubes (Ø26 x 360mm) - Door activated
Internal door opening size:	4 door openings: 570mm high x 365mm wide
Doors:	Solid stainless steel, self-closing doors (with key lock) - LH & RH hinged
Worktop (optional):	Accepts 10 x 1/3 150mm deep pans or 20 x 1/6 150mm deep pans
Shelves:	Two levels of non-tip, adjustable tray slides and/or shelves per door
Weight:	175 kg

SKOPE Industries Limited reserve the right to alter specifications without notice.

PSS0193 Rev 3.0 May 2012



SKOPE INDUSTRIES LIMITED



New Zealand Freephone: 0800 947 5673, Fax: (03) 983 3896. Australian Freephone: 1800 121 535, Freefax: 1800 121 533

Email: enquiry@skope.co.nz Website: www.skope.co.nz