

Modular Cooking Range Line 900XP 4 Electric Hot Plate Range on Electric Oven

ITEM # _____

MODEL # _____

NAME # _____

SIS # _____

AIA # _____

391041 (E9ECEH4QE0)

4-Hot Square Plates (4 kW each) electric Range on electric Oven (6 kW)

391167 (E9ECEH4QEN)

4-Hot Plate (4 kW each) electric Range on electric Oven (6 kW)

Short Form Specification

Item No. _____

Unit to be Electrolux Professional 900XP four 4kW electric hot plate range on electric oven. Electric characteristics to be _400V or _230V. Unit to be installed on stainless steel feet with height adjustment up to 50 mm. Unit to have cast-iron hot plates hermetically sealed to the one-piece top. Oven chamber with 3 levels of runners to accommodate 2/1 GN shelves (2 steam pans). Unit to have ribbed, cast-iron oven base plate. Exterior panels of unit in Stainless steel with Scotch Brite finish. Extra strength work top in heavy duty 2 mm Stainless steel. Unit has right-angled side edges to allow flush-fitting junction between units.

Main Features

- Unit to be mounted on stainless steel feet with height adjustment up to 50 mm. Unit can be easily mounted on cantilever systems.
- The four 4kW electric cast-iron hot plates are hermetically sealed to the one piece top and are featured with safety thermostat.
- Base compartment consists of an electric standard oven with 40 mm thick oven door for heat insulation, positioned beneath the base plate.
- Oven chamber with 3 levels of runners to accommodate 2/1 GN shelves (2 steam pans).
- Ribbed cast iron oven base plate.
- Oven to feature separate thermostats for top and bottom elements. Thermostat temperature adjustable from 110°C to 285°C.
- The special design of the control knob system guarantees against water infiltration.
- IPX5 water protection.
- Top configuration allows installation on ambient base only (not possible to install on refrigerated nor freezer base).

Construction

- Unit is 930 mm deep to give a larger working surface area.
- All exterior panels in Stainless Steel with Scotch Brite finishing.
- AISI 304 stainless steel worktop, 2mm thick.
- Model has right-angled side edges to allow flush fitting joints between units, eliminating gaps and possible dirt traps.

Included Accessories

- 1 of GN2/1 chrome grid for static oven PNC 164250

Optional Accessories

- GN2/1 chrome grid for static oven PNC 164250
- Pair of cast iron plate bars for electric cooking top PNC 206056
- Junction sealing kit PNC 206086
- Kit 4 wheels - 2 swivelling with brake - it is mandatory to install Base support and wheels PNC 206135
- Flanged feet kit PNC 206136
- Frontal kicking strip for concrete installation, 800mm PNC 206148
- Frontal kicking strip for concrete installation, 1000mm PNC 206150
- Frontal kicking strip for concrete installation, 1200mm PNC 206151

APPROVAL: _____

- Frontal kicking strip for concrete installation, 1600mm PNC 206152
- Pair of side kicking strips for concrete installation PNC 206157
- Frontal kicking strip, 800mm (not for refr-freezer base) PNC 206176
- Frontal kicking strip, 1000mm (not for refr-freezer base) PNC 206177
- Frontal kicking strip, 1200mm (not for refr-freezer base) PNC 206178
- Frontal kicking strip, 1600mm (not for refr-freezer base) PNC 206179
- Pair of side kicking strips (not for refr-freezer base) PNC 206180
- 2 panels for service duct for single installation PNC 206181
- 2 panels for service duct for back to back installation PNC 206202
- Kit 4 feet for concrete installation (not for 900 line free standing grill) PNC 206210
- Water column with swivel arm (water column extension not included) PNC 206289
- Water column extension for 900 line PNC 206290
- Chimney upstand, 800mm PNC 206304
- Back handrail 800 mm PNC 206308
- Back handrail 1200 mm PNC 206309
- Base support for feet or wheels - 800mm (700/900) PNC 206367
- Base support for feet or wheels - 1200mm (700/900) PNC 206368
- Base support for feet or wheels - 1600mm (700/900) PNC 206369
- Base support for feet or wheels - 2000mm (700/900) PNC 206370
- Rear paneling - 800mm (700/900) PNC 206374
- Rear paneling - 1000mm (700/900) PNC 206375
- Rear paneling - 1200mm (700/900) PNC 206376
- Chimney grid net, 400mm (700XP/900) PNC 206400
- Side handrail-right/left hand (900XP) PNC 216044
- Frontal handrail, 800mm PNC 216047
- Frontal handrail, 1200mm PNC 216049
- Frontal handrail, 1600mm PNC 216050
- 2 side covering panels for free standing appliances PNC 216134
- Large handrail - portioning shelf, 800mm PNC 216186

Front

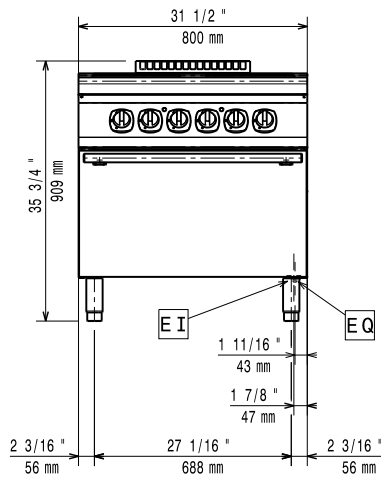

Side

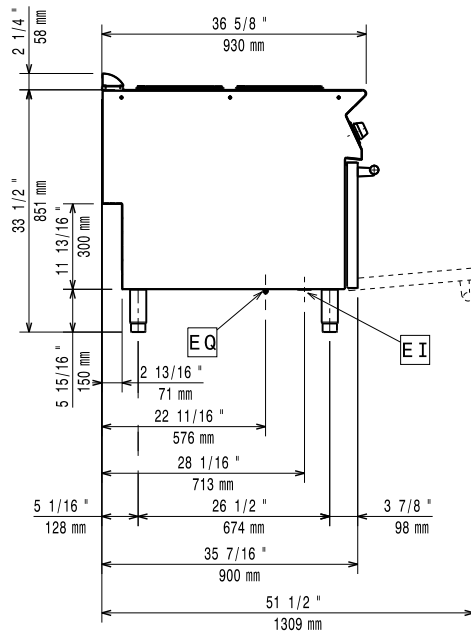

EI = Electrical inlet (power)
 EQ = Equipotential screw

Top

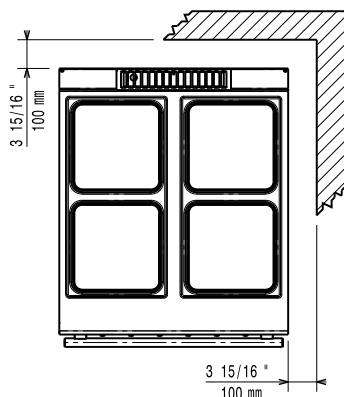

Electric

Supply voltage:

391041 (E9ECEH4QE0) 380-400 V/3N ph/50/60 Hz

391167 (E9ECEH4QEN) 230 V/3 ph/50/60 Hz

Electrical power max.: 22 kW

Total Watts: 22 kW

Predisposed for:

391041 (E9ECEH4QE0) 380-400V 3N- 50/60Hz
 20-22kW

Key Information:

Front Plates Power: 4 - 4 kW
 Back Plates Power: 4 - 4 kW
 Front Plates dimensions: 300x300 300x300
 Back Plates dimensions: 300x300 300x300
 Oven Heat Input: 6 kW
 Oven working Temperature: 110 °C MIN; 285 °C MAX

Oven Cavity Dimensions (width): 575 mm
 Oven Cavity Dimensions (height): 300 mm
 Oven Cavity Dimensions (depth): 700 mm
 External dimensions, Width: 800 mm
 External dimensions, Depth: 930 mm
 External dimensions, Height: 850 mm

Net weight:

391041 (E9ECEH4QE0) 120 kg

391167 (E9ECEH4QEN) 145 kg

Shipping weight:

391041 (E9ECEH4QE0) 142 kg

391167 (E9ECEH4QEN) 170 kg

Shipping height:

391041 (E9ECEH4QE0) 1080 mm

391167 (E9ECEH4QEN) 1120 mm

Shipping width:

1020 mm

Shipping depth:

860 mm

Shipping volume:

391041 (E9ECEH4QE0) 0.95 m³

391167 (E9ECEH4QEN) 0.98 m³

If appliance is set up or next to or against temperature sensitive furniture or similar, a safety gap of approximately 150 mm should be maintained or some form of heat insulation fitted.

Certification group:

391041 (E9ECEH4QE0) EH94O

391167 (E9ECEH4QEN) N9CE1