

## R55-B/07 700mm



Compact table-top sheeter with folding tables. Work cycle directions with joy-stick, stainless steel cylinder guards with safety micro switch and gas spring. Flour dust container.

### FEATURES

- Bench sheeter
- Manual joy stick control
- 60 x 500mm roller
- 0-38mm roller gap
- 500 x 700 fold away tables

## R55-B/07 700mm

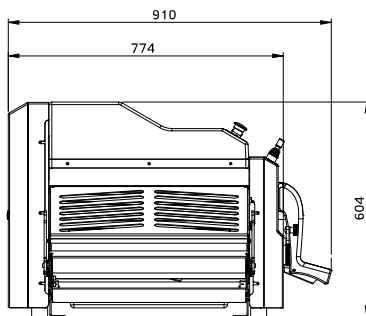
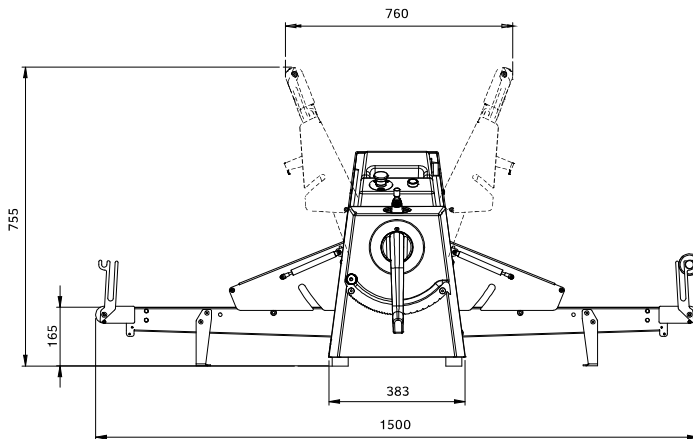

### SPECIFICATIONS

#### Dimensions

Width 1500mm  
Depth 910mm  
Height 755mm

Nett weight  
120kg

#### Power

0.55kw, 3 phase + Earth. 400V

#### Options

Dough trays



moffat.com.au  
moffat.co.nz

Australia  
moffat.com.au

#### Moffat Pty Limited

Victoria/Tasmania  
740 Springvale Road  
Mulgrave, Victoria 3170  
Telephone +613-9518 3888  
Facsimile +613-9518 3833  
vsales@moffat.com.au

#### New South Wales

Telephone +612-8833 4111  
nswsales@moffat.com.au

#### South Australia

Telephone +613-9518 3888  
vsales@moffat.com.au

#### Queensland

Telephone +617-3630 8600  
qldsales@moffat.com.au

#### Western Australia

Telephone +618-9413 2400  
wasales@moffat.com.au

#### New Zealand

moffat.co.nz

#### Moffat Limited

#### Rolleston

45 Illinois Drive  
Izone Business Hub  
Rolleston 7675  
Telephone +64 3-983 6600  
Facsimile +64 3-983 6660  
sales@moffat.co.nz

#### Auckland

Telephone +64 9-574 3150  
sales@moffat.co.nz



© Copyright Moffat Ltd  
AN.R.01:19 / 1602