

Twin Plate Contact Toaster

The Pro-Series contact toasters are equipped with a host of features that improve performance, functionality and ease of cleaning.

Used in quick service restaurants around the globe, these are the true professionals' choice.



New energy saving plate selection control



Protective heat shield and rigid handle



Twin thermostat controls on rear of unit

FEATURES & BENEFITS

- Single piece stainless steel plate and protective upstand
- 2 top plates (188 x 300mm) and one large bottom plate (460 x 320mm)
- Excellent heat distribution across entire cooking surface
- Smooth internal corners for easy cleaning
- Large removable grease tray
- Easily removable protective heat shields for increased operational safety – dishwasher safe
- 3 mode operation – Both plates, bottom plate only and standby - For increased energy efficiency (Reduces energy costs during non-busy periods)
- Eight programmable timer settings with one touch operation to achieve consistent results
- The top-plates are assisted by gas struts to enable effortless and safe lifting operation and ensures gentle pressure for optimal toasting
- Design of lifting mechanism ensures the plate will not fall down and cause burns to operators
- Drip-proof ventilation grills on rear and side of unit
- Dual-adjustable thermostats at rear of unit control temperatures for operation modes
- LED timer display
- Cut proof, high temperature resistant blue polyurethane supplied cord



W.GPC62SC



SPECIFICATIONS

kW 2.2 Amps 10
Width 468 Depth 578
Height (open) 765 Height (Closed) 331
Weight 25kg

Dealer:

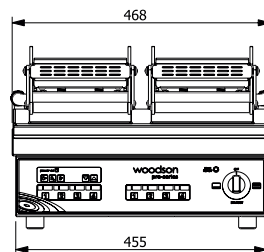

Front View

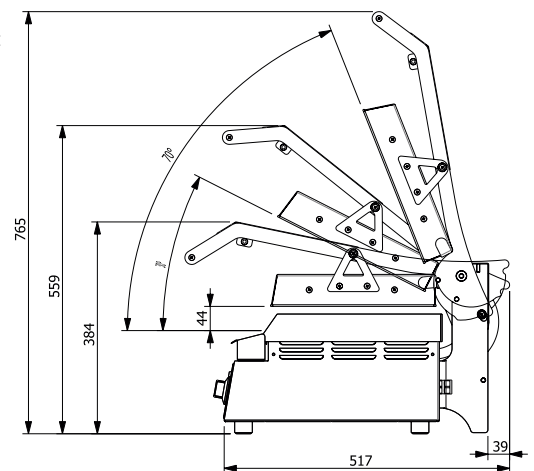

Side View

We reserve the right to alter specifications of products without notice. All dimensions are in mm.