

GOGRF15

PRODUCT FEATURES



- Double glazed, condensation free, glass on glass construction
- Sliding double glazed rear doors argon filled
- Deck forced refrigeration
- Double glazed with painted edges
- Adjustable glass shelf (additional shelf available)
- Ticket strips on shelf and deck
- Under shelf and canopy LED lights
- Integral condenser, self evaporating

Maximum shelf load weight 15kg spread evenly

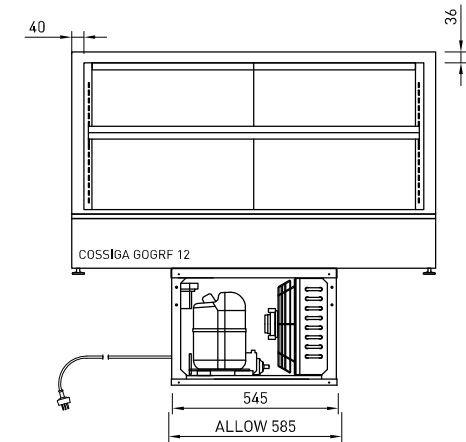
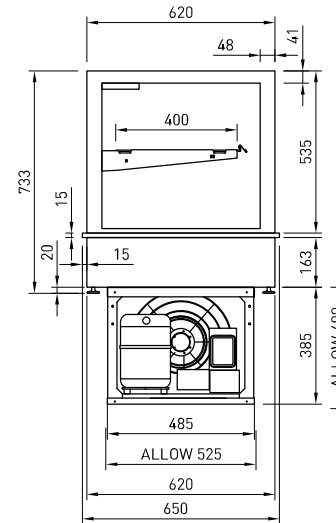
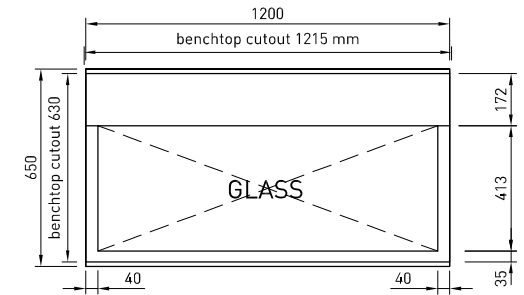

CABINET DIMENSIONS & SPECIFICATIONS

Prior to installation see, installation guidelines, ventilation requirements and drainage options documents

MODEL	CABINET			SHELVING	SHELVING	OPERATING TEMP	SHELF	BASE TRAY	TOTAL FOOD	DISPLAY M ²	INTERNAL VOLUME M ³	FREQUENCY	REFRIGERANT	POWER		CONNECTION ELECTRICAL POWER CORD 2200MM		VOLTAGE	PACKED FOR SHIPPING			
	LENGTH [MM]	DEPTH [MM]	HEIGHT [MM]	WEIGHT KG		DEG C	W X D	W X D	100MM UNITS					KWH	AMP	NZ/AUS 10 AMP	UK 13 AMP		LENGTH [MM]	DEPTH [MM]	HEIGHT [MM]	WEIGHT
GOGRF15	1500	650	733	195	1 + BASE	3-9	1390 X 430	1350 X 410	126	1.130	0.75	50/60 HZ	R290	1.11	4.8	3 PIN PLUG	3 PIN PLUG	220-240V	1600	750	1255	202