

LPRF15

PRODUCT FEATURES

- Low Velocity air over refrigeration
- Dual canopy LED lights
- Adjustable deck height
- Integral condenser
- Self evaporating
- Polished glass front and sides
- Slide under and over perspex rear covers
- Ambient storage cabinet underneath
- Lockable castors
- Side and front panels available as an optional extra

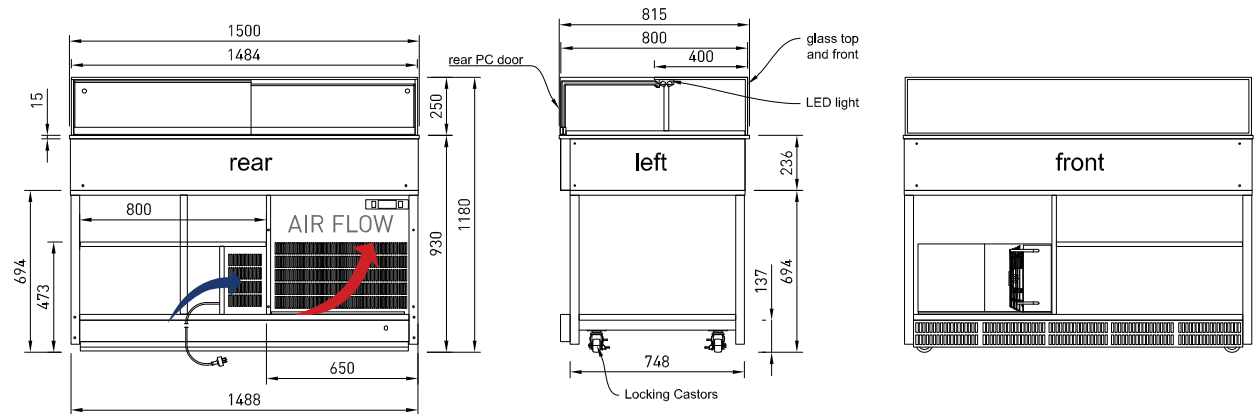
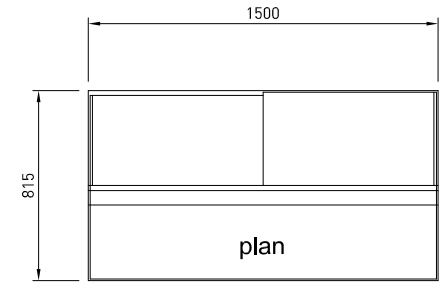

CABINET DIMENSIONS & SPECIFICATIONS

Prior to installation see, installation guidelines, ventilation requirements and drainage options documents

MODEL	CABINET			SHELVING WEIGHT KG	SHELVING	OPERATING TEMP DEG C	SHELF W X D	BASE TRAY W X D	TOTAL FOOD 100MM UNITS	DISPLAY M ²	INTERNAL VOLUME M ³	FREQUENCY HZ	REFRIGERANT	POWER		CONNECTION ELECTRICAL POWER CORD 2200MM		VOLTAGE	PACKED FOR SHIPPING			
	LENGTH [MM]	DEPTH [MM]	HEIGHT [MM]											KW 230V	AMP	NZ/AUS 10 AMP	UK 13 AMP		LENGTH [MM]	DEPTH [MM]	HEIGHT [MM]	WEIGHT
LPRF15	1500	815	1180	270	BASE	3-9	N/A	1400 X 750	98	0.85	0.26	50/60 HZ	R290	1.04	4.5	3 PIN PLUG	3 PIN PLUG	220-240V	1600	920	1350	277